

# REVELER RVCL SERIES-W/ADJUSTABLE BRACKET

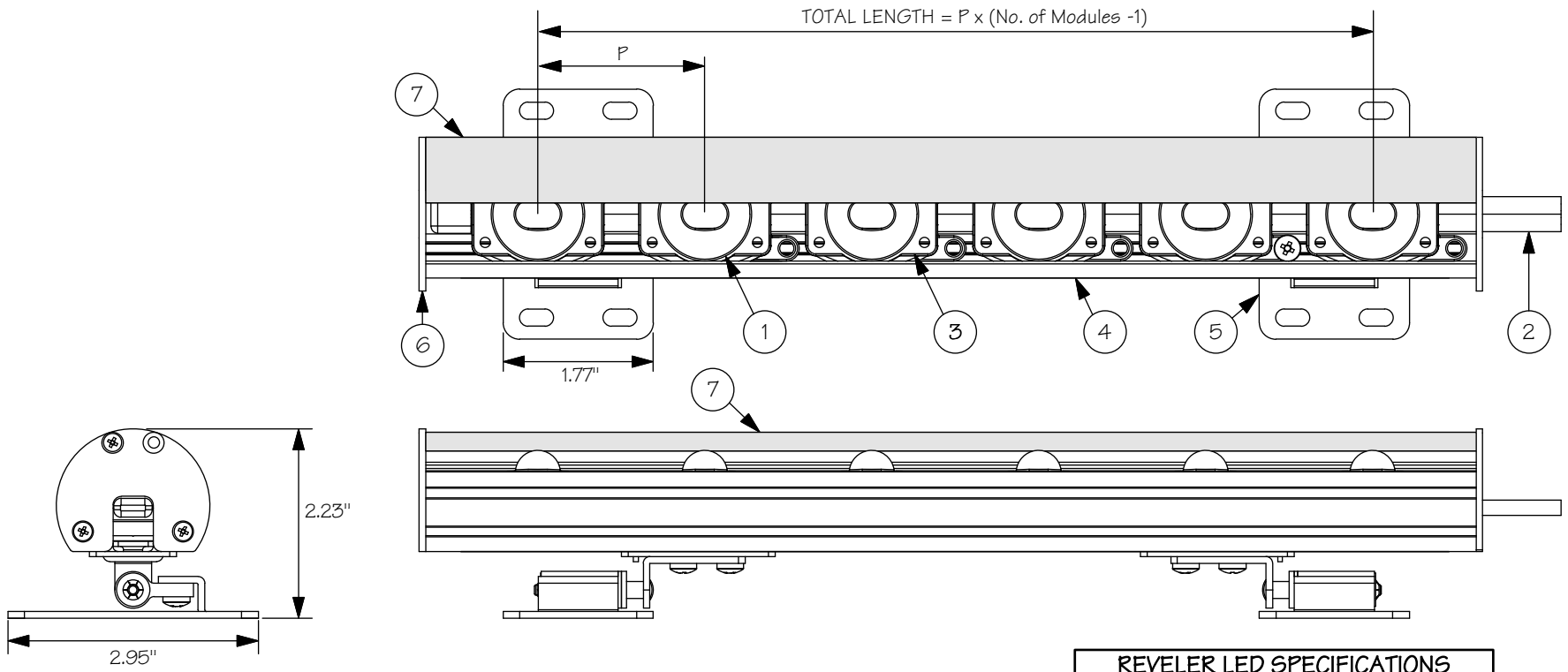

CATALOG#	P (INCH)	LENS	MAX. LENGTH	WEIGHT
RVCL-50-(2700K, 3000K, 5500K, BL)-120°	2 ± .08"	120°	8 FT.	378g / 1.83 lb PER FT.
RVCL-50-(2700K, 3000K, 5500K, BL)-SP	2 ± .08"	SPREAD	8 FT.	378g / 1.83 lb PER FT.
RVCL-100-(2700K, 3000K, 5500K, BL)-120°	4 ± .08"	120°	8 FT.	326g / 1.72 lb PER FT.
RVCL-100-(2700K, 3000K, 5500K, BL)-SP	4 ± .08"	SPREAD	8 FT.	326g / 1.72 lb PER FT.
RVCL-150-(2700K, 3000K, 5500K, BL)-120°	6 ± .08"	120°	8 FT.	300g / 1.66 lb PER FT.
RVCL-150-(2700K, 3000K, 5500K, BL)-SP	6 ± .08"	SPREAD	8 FT.	300g / 1.66 lb PER FT.

REVELER LED SPECIFICATIONS		
VOLTAGE: 12 VAC		
CURRENT: 150mA PER LED		
POWER: 1.8W PER LED		
LED CODE	COLOR	OUTPUT
2700K	2700K	66 Lm
3000K	3000K	68 Lm
5500K	5500K	77 Lm
BL	BLUE	20 Lm
LENS CODE	STYLE	
120D	120° LENS	
SP	25° x 80° SPREAD LENS	



**TOKISTAR LIGHTING INC.**  
 1015 E. DISCOVERY LANE  
 ANAHEIM, CA 92801  
 TEL: 714 772 7005 FAX: 714 772 7014  
 email: info@tokistar.com Website: tokistar.com

REVELER SERIES SUBMITTAL	NO.	PART	MATERIAL
CATALOG#: RVCL-(50, 100, 150,BL)-(LED CODE)-(LENS CODE)	1	LED	SOLID STATE LED
DATE: MAY 26, 2020	2	CABLE	PVC INSULATION WITH PLATED #12 AWG X 2
DRAWN BY: R. CORDOVA	3	LED MODULE COVER	ALUMINUM DIE CAST
SCALE: 1:2	4	CHANNEL	ANODIZED ALUMINUM (SILVER)
	5	ADJUSTABLE BRACKET	STAINLESS STEEL
	6	CHANNEL END CAP	STAINLESS STEEL
	7	LOUVER	ANODIZED ALUMINUM