



TOKISTAR LIGHTING INSTRUCTION MANUAL

Trillium™ Series

General Description

Tokistar's Trillium Series is an 8 VDC lighting system using 0.32 Watt Tri-Color LEDs sealed to a flexible cable. Each fixture has Blue, Red, Green and Black color-coded wire.

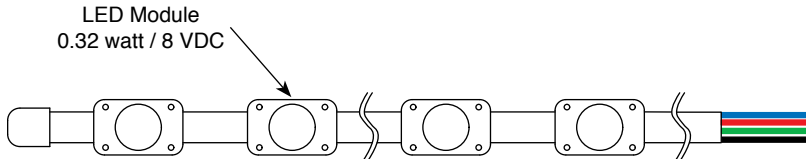

Light Source	
Description	Part No.
2" O.C. 0.32 Watt LED	TRI-50-RGB
4" O.C. 0.32 Watt LED	TRI-100-RGB
6" O.C. 0.32 Watt LED	TRI-150-RGB
12" O.C. 0.32 Watt LED	TRI-300-RGB

Secondary Circuit Wiring

To minimize voltage drop and keep conductors safely within their rating, do not exceed the maximum lengths shown for each independent fixture.

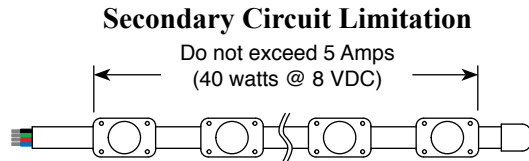

Maximum Run Lengths	
LED Spacing	Length
2" (50 mm)	20' 10" (6.25 M)
4" (100 mm)	41' 8" (12.5 M)
6" (150 mm)	50' (15 M)
12" (300 mm)	70' (21 M)

To determine the proper size of the secondary wire, the distance from the fixture to the LED Driver and the LED spacing of the fixture need to be considered. The chart to the right indicates recommended wire size based on these two variables.

Wire Size	2" O.C. Spacing	4", 6", 12" O.C. Spacing
	Wire Length	Wire Length
#16 AWG	30' (9.2 M)	20' (6 M)
#14 AWG	36' (11 M)	20' (6 M)
#12 AWG	40' (12 M)	25' (7.5 M)
#10 AWG	60' (18 M)	30' (9.2 M)

⚠️ PRECAUTIONS

1. Read all instructions completely before beginning installation.
2. Turn off electricity before beginning installation.
3. All wiring is to be performed by a qualified electrician.
4. Installation must comply with the National Electrical Code, and all applicable codes.
5. Turn main supply to the LED Driver on only after all connections have been made and tested.
6. Use only LED Drivers provided by Tokistar with the system.
7. Certain adhesives produce a bi-product of corrosive gas during their curing process, and should not be used in conjunction with our LED Systems where the gas cannot be vented. Consult with the Sealant company for such applications.

TOKISTAR® LIGHTING

1015 E. Discovery Lane
Anaheim, CA 92801
TEL: 714 772 7005 FAX: 714 772 7014
email: info@tokistar.com Website: tokistar.com

Installation Instructions

Mounting Trillium Fixtures

Option 1 - Mounting Track (Part #: TRI-MT)

A PVC mounting track may have been provided with your material. The track can be attached with screws, construction adhesive or hi-bond adhesive. If attached with screws, install them every 8" on center. Once the track is securely in place, snap in the LED modules.

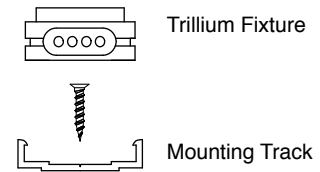

Option 2 - Panel Fastener (Part #: TRI-PF)

Panel fasteners consist of two parts. The upper part of the fastener is inserted through the top of the panel. The bottom part of the fastener is attached to the base of the LED module. This assembly is then snapped into the upper part of the fastener.

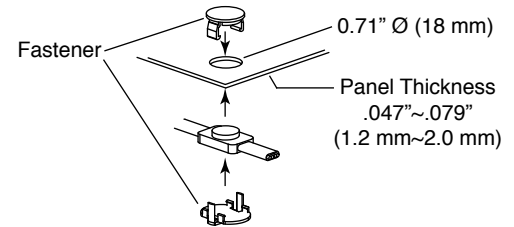

Option 3 - Mounting Clamp (Part #: TRI-MC)

For maximum flexibility, TokiLum may be installed with mounting clamps. Screw each clamp securely in place, then snap the clamp over the cable.

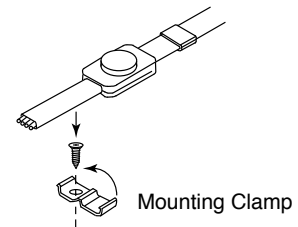

Mounting Trillium Channel

Trillium Fixtures may have been provided inside an aluminum channel. The channel base can be attached with screws, construction adhesive or hi-bond adhesive. If attached with screws, install them every 8" on center. Once the base is securely in place, snap the top of the channel into the base.

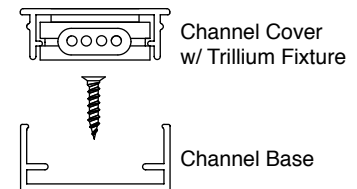

LED Driver Installation

LDR8-40

This 40 Watt UL Recognized Class 2 LED Driver converts an AC input into an 8 VDC output. Refer to the manual provided with the LED Driver for detailed installation instructions.

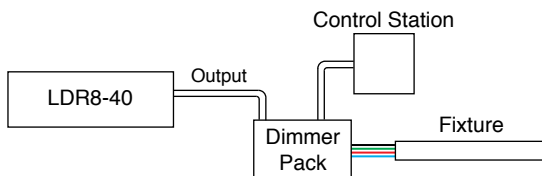

LDR8-80

This dual output Class 2 LED Driver has two independent 40 Watt outputs. Refer to the manual provided with the LED Driver for detailed installation instructions.

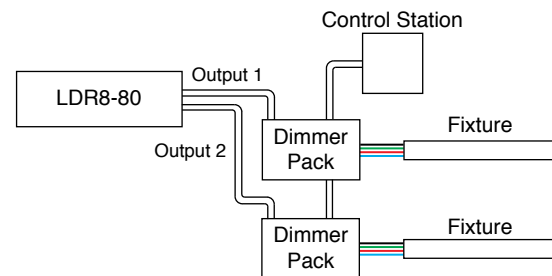

Trillium is a
Wet-Location Listed System
when operated from
our LED Drivers



Part#	Input Volts	Output Volts	Output Ratings
LDR8-40	100~240	8 VDC	1 @ 5 Amps
LDR8-80	100~240	8 VDC	2 @ 5 Amps

Lighting Controllers

Color Mix System

There are three basic components to the control system. They include: the Control Station, Dimmer Packs and LED Drivers.

Part #: LC-3CH-CM

The LC-3CH-CM Control Station installs in a double-gang junction box. Power to this unit comes from the LED Driver connected to the first dimmer pack. A 50 foot CAT5 cable is provided.

Part #: LC-3CH-DP

Dimmer packs are capable of operating up to 125 LED modules. A CAT5 cable is provided with each unit. Up to 25 dimmer packs may be connected in series if the total length of all CAT5 cable does not exceed 165 feet from the LC-3CH-CM control station to the last dimmer pack.

For further information, refer to the instruction manuals provided with the units.

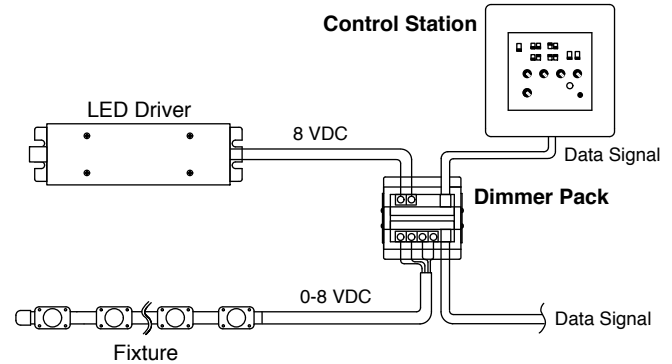

DMX Dimming System

Dimmer Packs are addressable, and may be used with any controller working on DMX protocol.

Part #: LC-3CH-DMX

DMX Dimmer Packs are capable of operating up to 125 each 0.32 LEDs (40 Watts maximum).

Up to 36 Dimmer Packs can be linked together with Data Cable. For applications exceeding 36 Dimmer Packs, a Splitter is required. Splitters can operate an unlimited number of Dimmer Packs.

For further information, refer to the instruction manuals provided with the units.

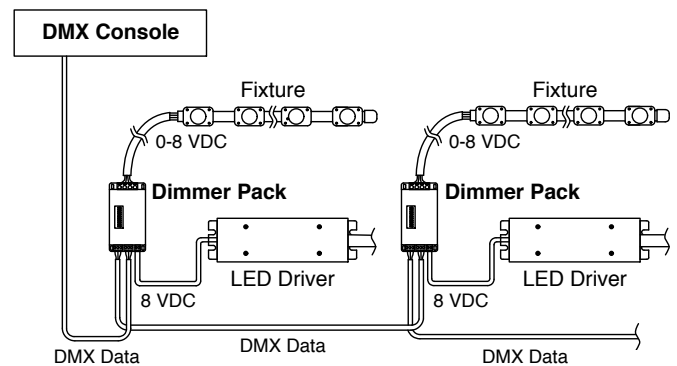

PRECAUTION

All dimming components are rated for dry location only. They must be installed within an enclosure suitable for the environment.