



TOKISTAR LIGHTING INSTRUCTION MANUAL

Gradient Series

24 VDC

General Description

Tokistar's Gradient Series is a 24 VDC lighting system with 2.5 watt LED light sources available on 3" (75 mm) or 4" (100 mm) centers. Light sources are enclosed within an aluminum channel. Each Gradient fixture is labeled with its appropriate load.

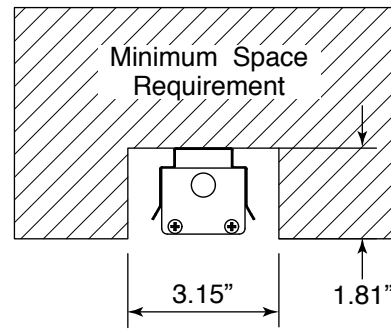
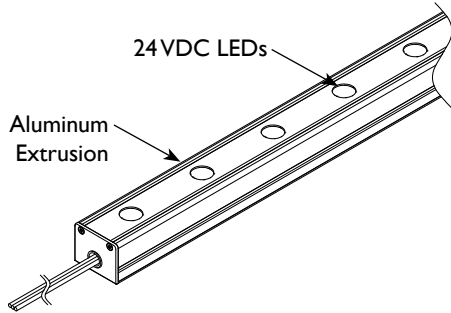

Mounting Fixtures

Option 1 - Fixed Mounting Bracket

Securely attach Mounting Brackets with screws, and then snap the Gradient Extrusion in place. A minimum of two brackets is required. For fixtures exceeding 5 feet (1.5 M), three brackets are required.

Option 2 - Adjustable Mounting Bracket

Securely attach the Adjustable Brackets with screws, and then snap the Gradient Extrusion in place. The bracket can rotate up to 60° from side to side. For fixtures with up to four LED modules, a single bracket is all that is required. Fixtures exceeding four LED modules require two brackets.

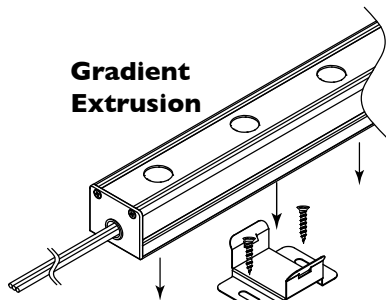

Mounting Bracket
Securely attach with screws.

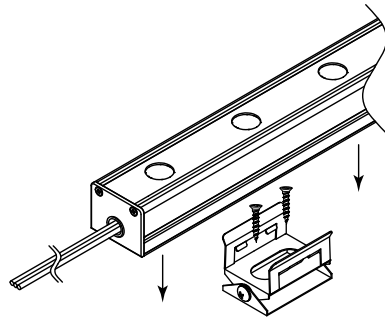

Adjustable Bracket
Securely attach with screws.

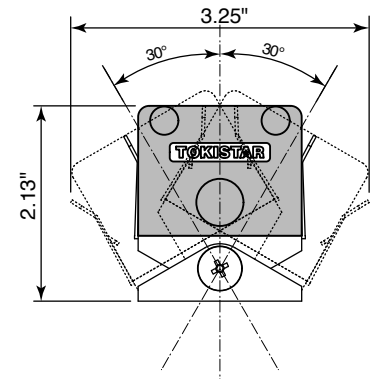

⚠ PRECAUTIONS

1. Read all instructions completely before beginning installation.
2. Turn off electricity before beginning installation.
3. All wiring is to be performed by a qualified electrician.
4. Installation must comply with the National Electrical Code, and all applicable codes.
5. Turn main supply to LED Driver on only after all connections have been made and tested.
6. Use only LED Drivers provided by Tokistar with the system.

TOKISTAR® LIGHTING

1015 E. Discovery Lane
Anaheim, CA 92801
TEL: 714 772 7005 FAX: 714 772 7014
email: info@tokistar.com Website: tokistar.com

Secondary Circuit Limitation

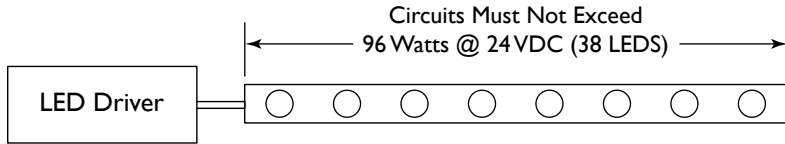

Recommended Lead Wire Size

The distance from the LED Driver to the fixture, and the load of the fixture, will determine the proper size of secondary wire. The chart on the right indicates recommended wire size based on an individual driver output being loaded to its full capacity of 4 Amps / 96 Watts.

Secondary Lead Wires	
Wire Size	Wire Length
#18 AWG	46' (14 M)
#16 AWG	59' (18 M)
#14 AWG	98' (30 M)
#12 AWG	148' (45 M)
#10 AWG	230' (70 M)

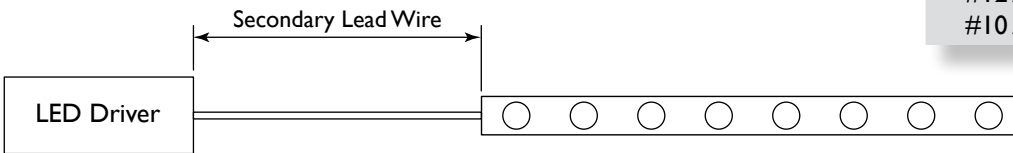

LED Driver Installation

LDR24-96

This 96 Watt Class 2 LED Driver converts an AC input into a 24 VDC output. Refer to the manual provided with the LED Driver for detailed installation instructions.

Part#	Input Volts	Output Volts	Output Ratings
LDR24-96	100~277	24VDC	1 @ 4 Amps

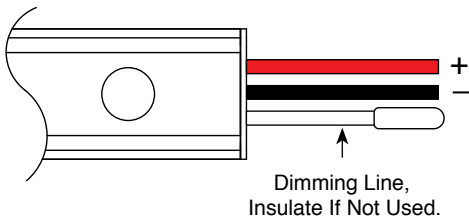

For dimming purposes, Gradient is supplied with a dimming line. When the system is not dimmed, insulate the dimming line with a wire nut or other appropriate means.

Dimming with LC-1CH-Multi Dimming Converter

The LC-1CH-MULTI Dimming Converter is required if Gradient is to be controlled from dimming systems operating on DMX or 0/1-10VDC protocols. Each converter can operate up to 25 LC-GR-DP dimmer packs. For projects exceeding this count, multiple converters can be wired in series and each will operate up to 25 dimmer packs.

DMX Mode - In this mode, each unit is independently addressable. Convenient In-Out terminals are provided for connecting units in series.

ANALOG Modes - You may select between 0-10V or 1-10V Analog protocols. Convenient In-Out terminals are provided for connecting units in series.

For further information, refer to the instruction manual provided with the LC-1CH-MULTI.

Dimmer Pack - Part #: LC-GR-DP

Each dimmer pack receives a 24 VDC input from an LDR24-96 LED Driver. Up to 25 dimmer packs can be connected in series if the total length of all CAT5 cable does not exceed 165 ft. (50 M). A CAT5 cable is provided with each unit.

For further information, refer to the instruction manual provided with the LC-GR-DP.

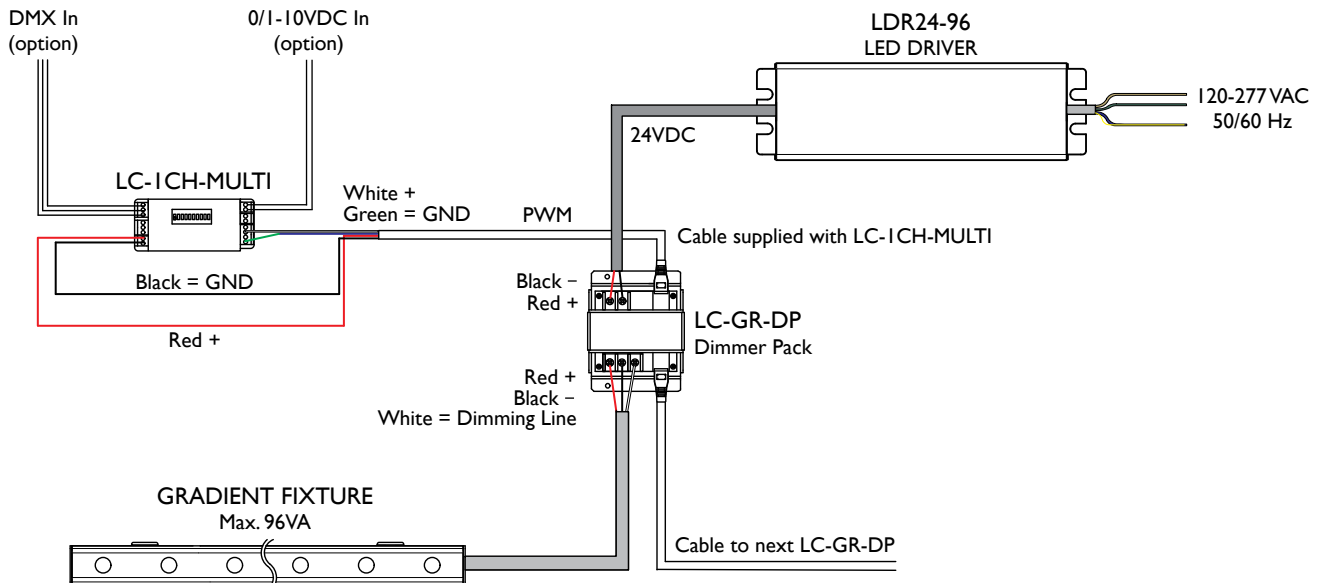

DMX Control Mode

For operation from devices using DMX protocol, flip dip-switch 10 to the “ON” position.



On
↑
↓
Off

DMX is an acronym for Digital Multiplex. This is a universal binary language used as a form of communication between intelligent devices. After setting dip-switch 10 to the “ON” position, you need to set the address on the dimmer pack. If all dimmer packs have the same address setting, all will work in unison. You can set dimmer packs to different addresses, so each one is operating independently.

Each dip-switch on the dimmer pack represents a binary value. A DMX address is set by combining the dip switches so they add up to the value you wish to achieve.

- Dip-Switch 1 address equals 1
- Dip-Switch 2 address equals 2
- Dip-Switch 3 address equals 4
- Dip-Switch 4 address equals 8
- Dip-Switch 5 address equals 16
- Dip-Switch 6 address equals 32
- Dip-Switch 7 address equals 64
- Dip-Switch 8 address equals 128
- Dip-Switch 9 address equals 256

Start CH#	Switches On	Start CH#	Switches On
1	1	11	1,2,4
2	2	12	3,4
3	1,2	13	1,3,4
4	3	14	2,3,4
5	1,3	15	1,2,3,4
6	2,3	:	:
7	1,2,3	:	:
8	4	:	:
9	1,4	:	:
10	2,4	511	1,2,3,4,5,6,7,8,9

Example 1

Dip Switch	Value
1	= 1
3	= 4
5	= 16
	= 21

Example 2

Dip Switch	Value
1	= 1
4	= 8
7	= 64
8	= 128
	= 201

Dimming Curve

There are two settings for the Dimming Curve.

With dip-switch 12 set to the “On” position, the Dimming Curve is Linear.

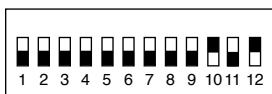

On
↑
↓
Off

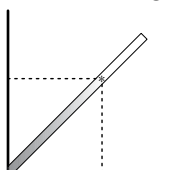

With dip-switch 12 set to the “Off” position, the Dimming Curve is Non-Linear.

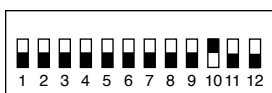

On
↑
↓
Off

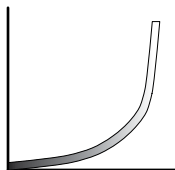

Analog Setting 1-10VDC

For operation from devices using 1-10VDC protocol, flip dip-switch 11 to the "ON" position.

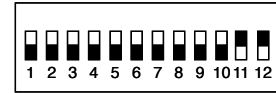

On
↑
↓
Off

The 1-10VDC setting is the norm in most cases, and does not require the system to send a separate power signal to the dimming device. The dimming device derives its power from our LED Driver. Additionally, this setting is based upon the protocol 0-1VDC = Off, and other voltage values above 1VDC directly correlate to dim values. A maximum of 10 Dimmer Packs can be connected in series.

Dimming Curve

In this analog mode, there are two settings for the Dimming Curve.

With dip-switch 12 set to the "On" position, the Dimming Curve is Linear.



On
↑
↓
Off

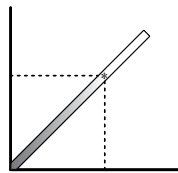

With dip-switch 12 set to the "Off" position, the Dimming Curve is Non-Linear.



On
↑
↓
Off

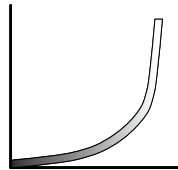

Analog Setting 0-10VDC

For operation from devices using 0-10VDC protocol, flip dip-switch 11 to the "Off" position.



On
 ↑
 ↓
 Off

The 0-10VDC setting is not the norm in most cases, and requires the system to send a separate power signal to the dimming device. The dimming device derives its power from some external source in this case, and not from our LED Driver. Additionally, this setting is based upon the protocol 0VDC = Off, and other voltage values directly correlate to dim values (eg. 8VDC= 80% brightness level). The maximum number of dimmer packs to be connected in series is based upon the capacity of the dimming device.

Dimming Curve

In this analog mode, there are two settings for the Dimming Curve.

With dip-switch 12 set to the "On" position, the Dimming Curve is Linear.

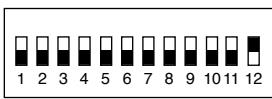

On
 ↓
 ↑
 Off

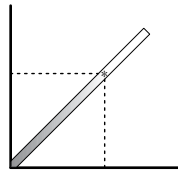

With dip-switch 12 set to the "Off" position, the Dimming Curve is Non-Linear.



On
 ↓
 ↑
 Off

